

Mir Module Movements

(docking cone placement)

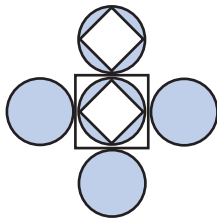

Mir
(launch)
Feb. 2, 86

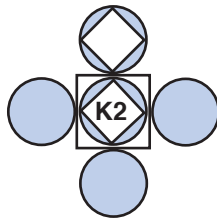

Kvant-2
(dock to -X)
Dec. 6, 89

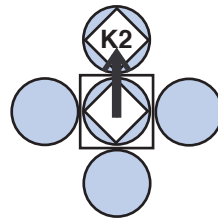

Kvant-2
(move -X to +Y)
Dec. 8, 89

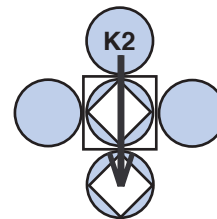

Cone
(move +Y to -Y in EVA)
Jan. 11, 90

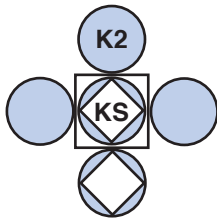

Kristall
(dock to +Y)
Jun. 10, 90

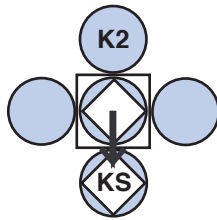

Kristall
(move +Y to -Y)
Jun. 11, 90

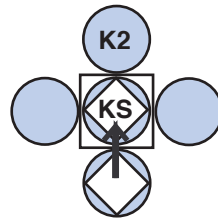

Kristall
(move -Y to -X)
May 26, 95

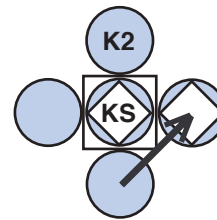

Cone
(move -Y to -Z in EVA)
May 28, 95

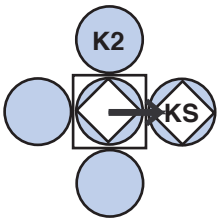

Kristall
(move -X to -Z)
May 29, 95

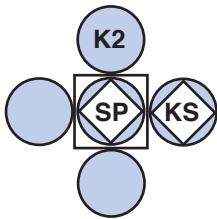

Spektr
(dock -X)
Jun. 1, 95

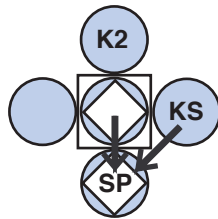

Cone (move -Z to -Y in EVA)
Jun. 1, 95
Spektr (move -X to -Y)
Jun. 2, 95

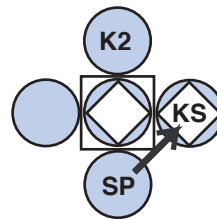

Cone
(move -Y to -Z no EVA)
Jun. 10, 95

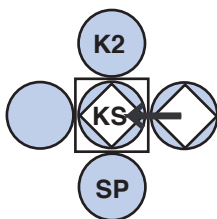

Kristall (move -Z to -X)
Jun. 10, 95
STS-71 (dock to Kristall at -X)
Jun. 29, 95

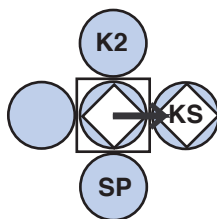

Kristall
(move -X to -Z)
Jul. 17, 95

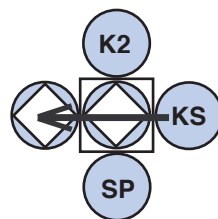

Cone
(move -Z to +Z in EVA)
Dec. 8, 95

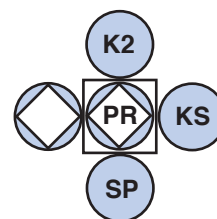

Priroda
(dock to -X)
Apr. 26, 96

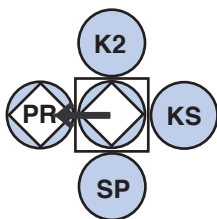

Priroda
(move -X to +Z)
Apr. 27, 96

Docking Port Key (interior of Mir looking forward to the -X port)

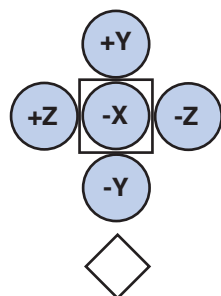

- +X Aft Mir axial port at Kvant -1
- X Forward Mir axial port at the multi-docking hub
- +Y Multi-docking hub upper port
- Y Multi-docking hub lower port
- +Z Multi-docking hub left (port side)
- Z Multi-docking hub right (starboard side)

Docking Cone

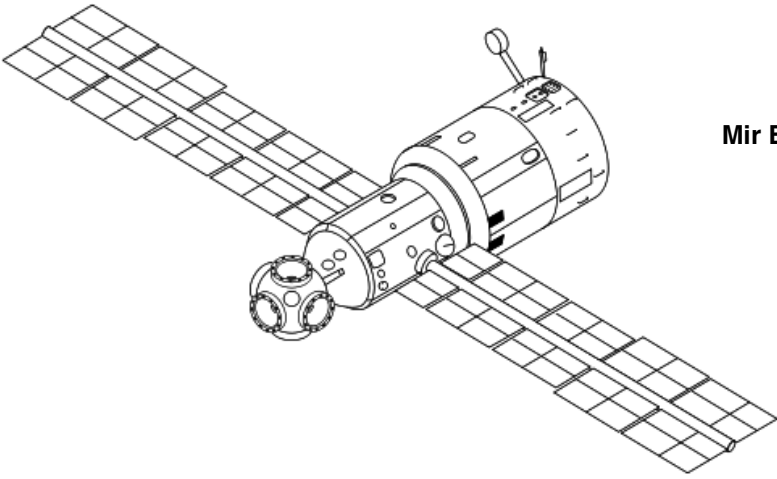

Mir Base Block launched Feb. 19, 1986

**Mir mated with Kvant Apr. 9, 1987
Note third central array added in EVAs
during Jun., 1987**

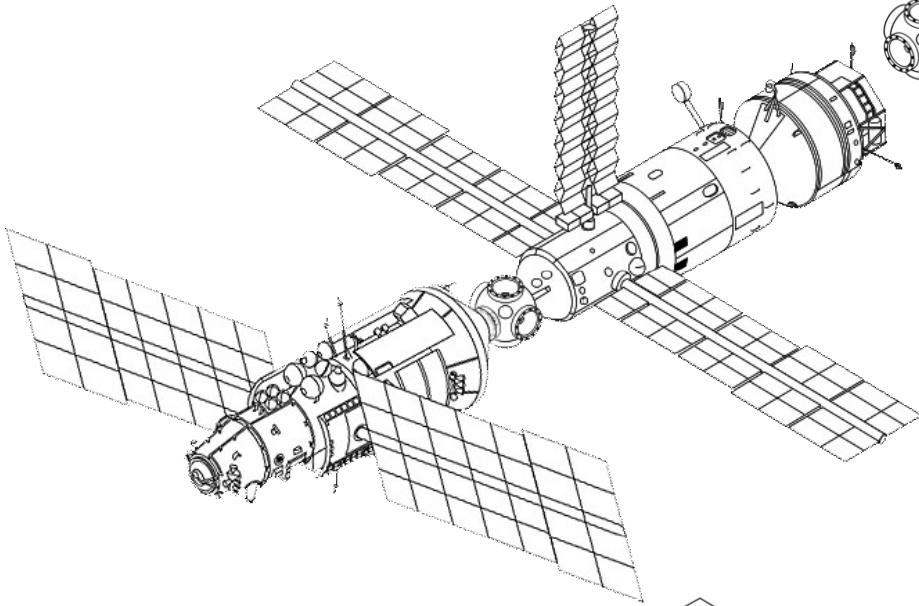
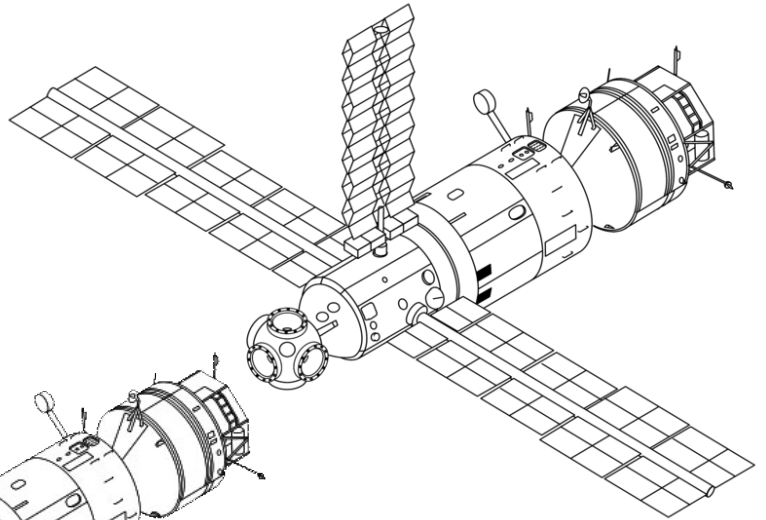

Kvant-2 docks Dec. 6, 89

**Kvant-2 repositions to the upper port
Dec. 8, 1989**

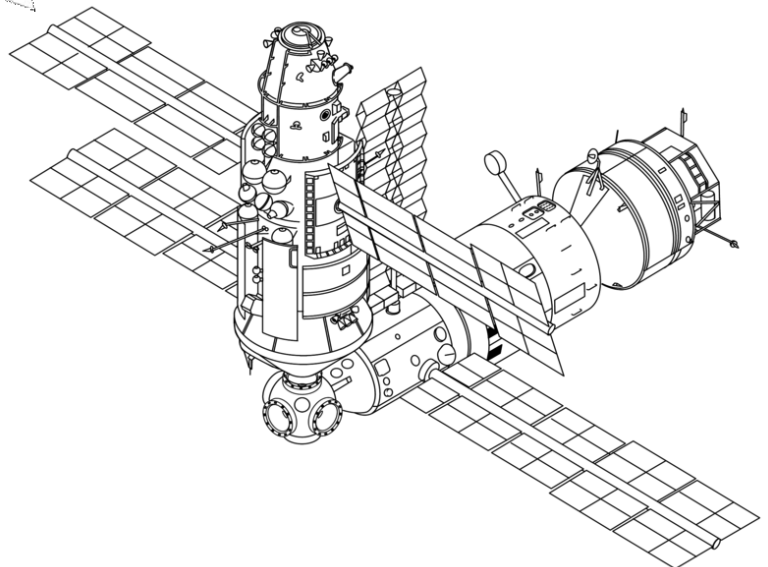

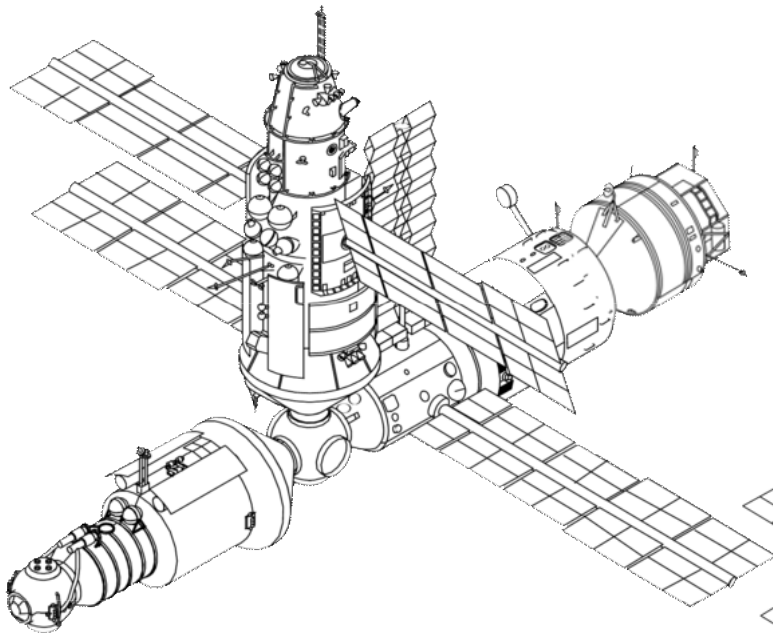

Kristall docks Jun. 10, 1990

**Kristall repositions to lower port
Jun. 11, 1990**

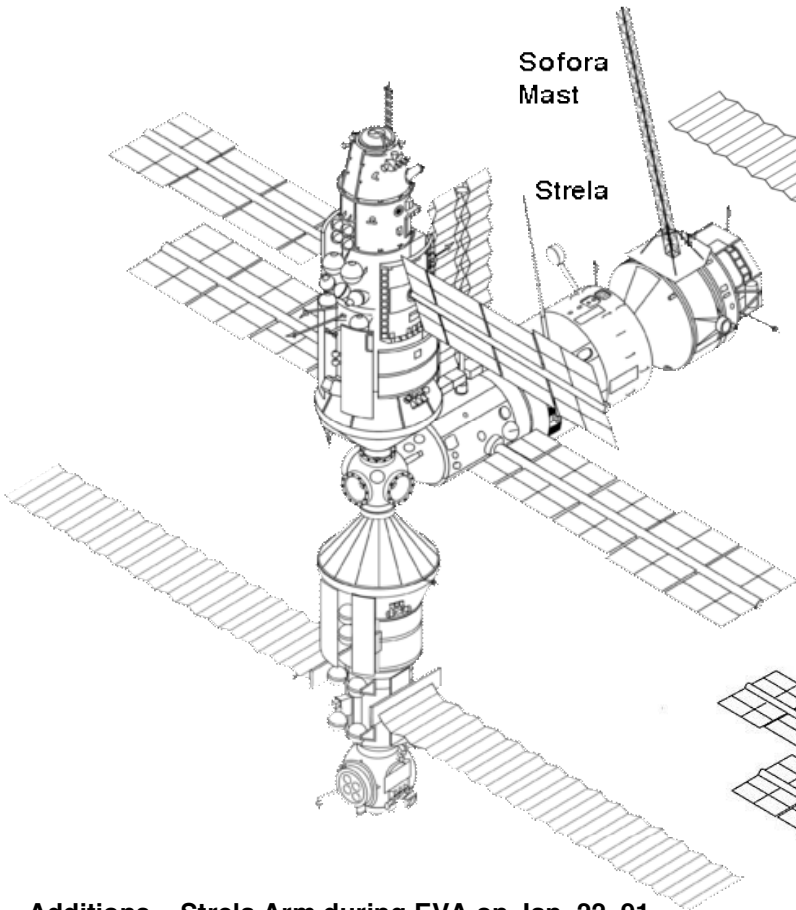
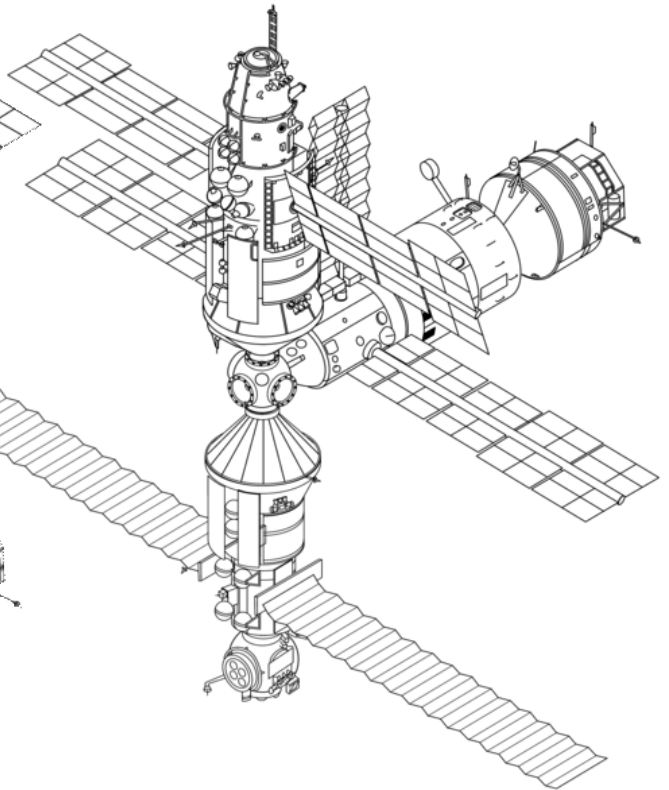

**Sofora
Mast**

Strela

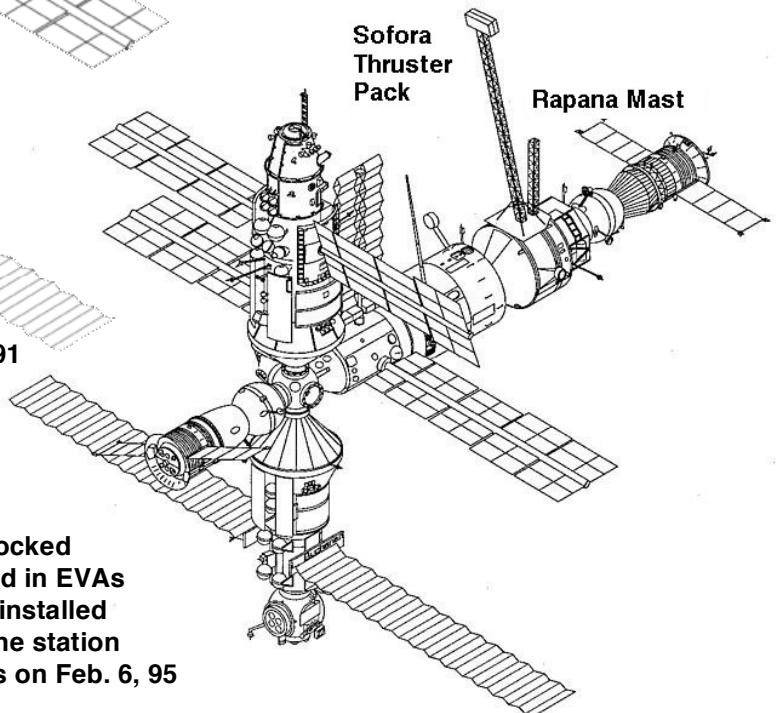

**Sofora
Thruster
Pack**

Rapana Mast

**Additions – Strela Arm during EVA on Jan. 22, 91
and the Sofora Mast during EVAs in Jul. 91**

**A view with Soyuz and Progress craft docked
Note Sofora Mast Thruster Pack installed in EVAs
during Sep., 1992 and the Rapana Mast installed
in EVAs during Sep. 1993. This is how the station
appeared during the STS-63 rendezvous on Feb. 6, 95**

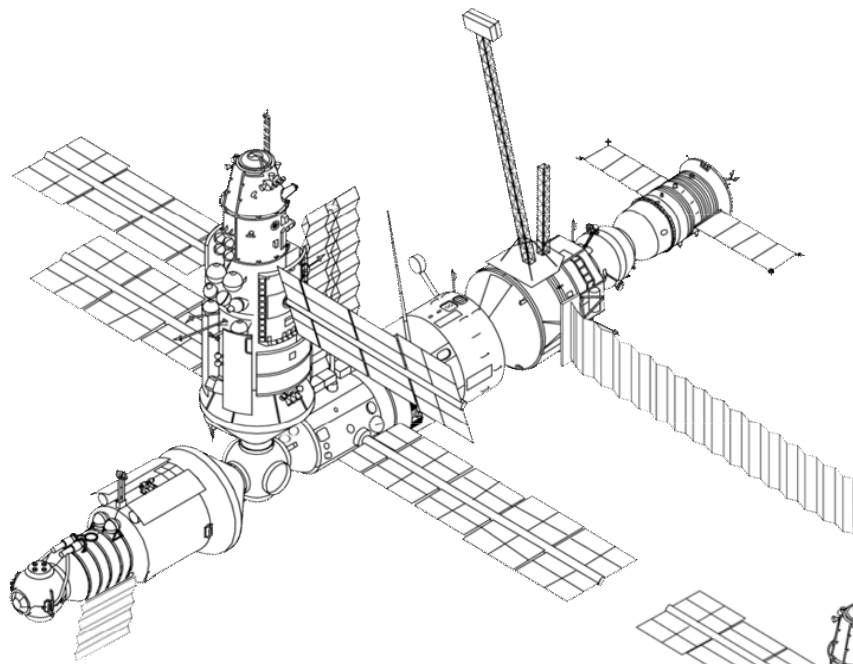

Kristall repositions up May 26, 95
Note one Kristall array retracted (60%)
with the second moved to the port side
of Kvant during EVAs that same month.

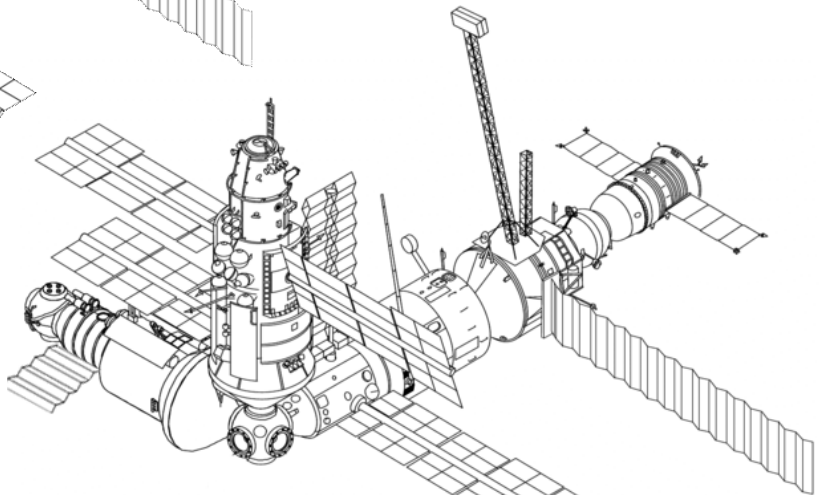

**Kristall repositions to the starboard side
May 29, 95**

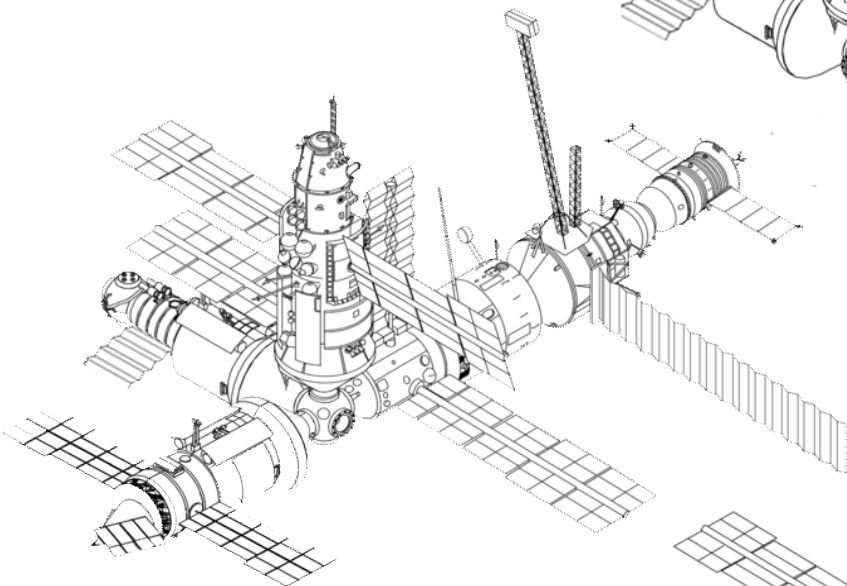

Spektr docks Jun. 1, 95

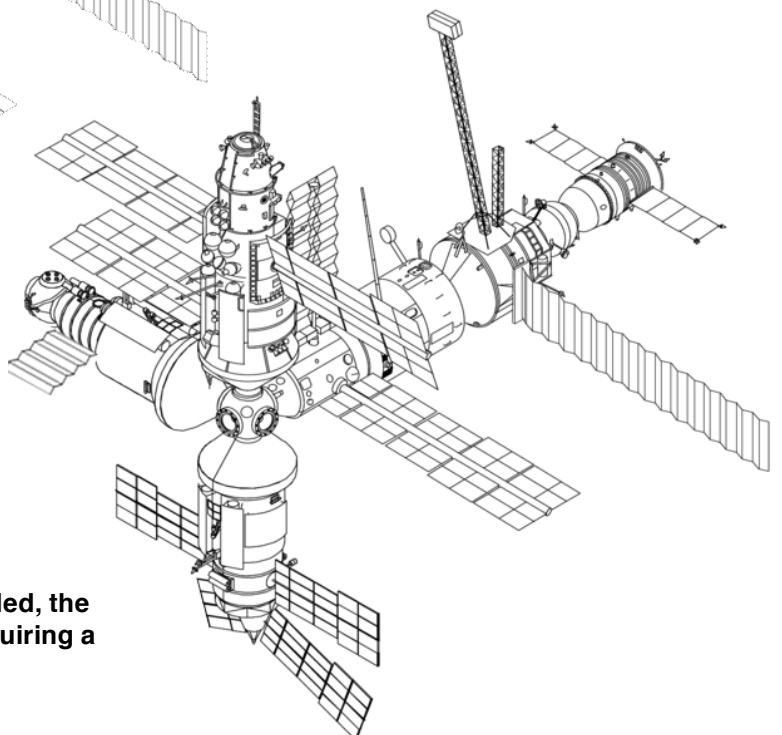

Spektr repositions down Jun. 2, 95
Note 2nd pair of Solar Arrays unfurled, the
Starboard set only partially and requiring a
future EVA

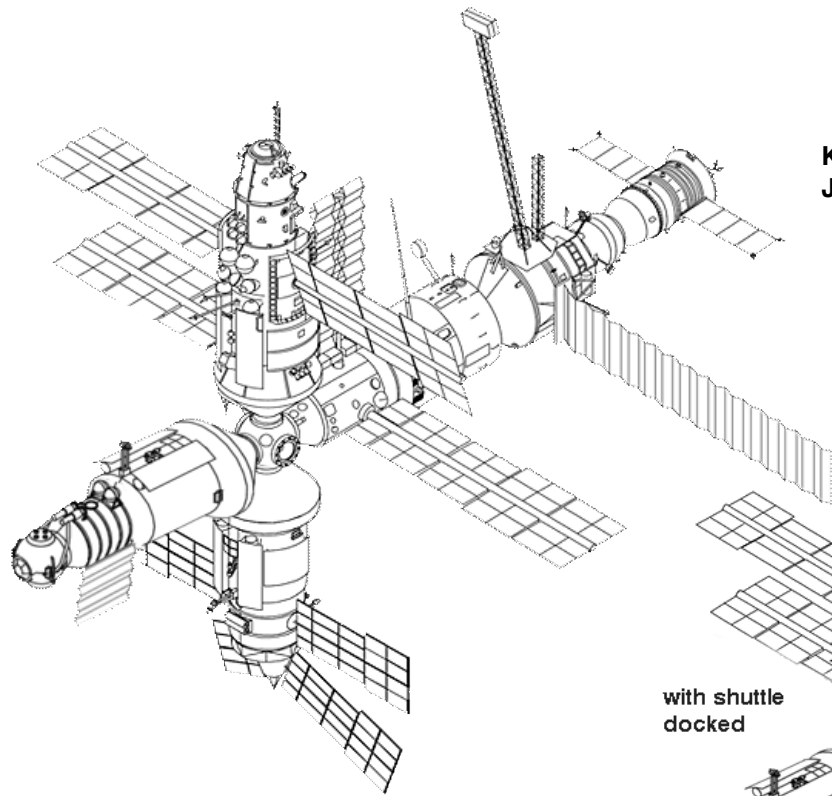

**Kristall repositions to central port
Jun. 10, 95**

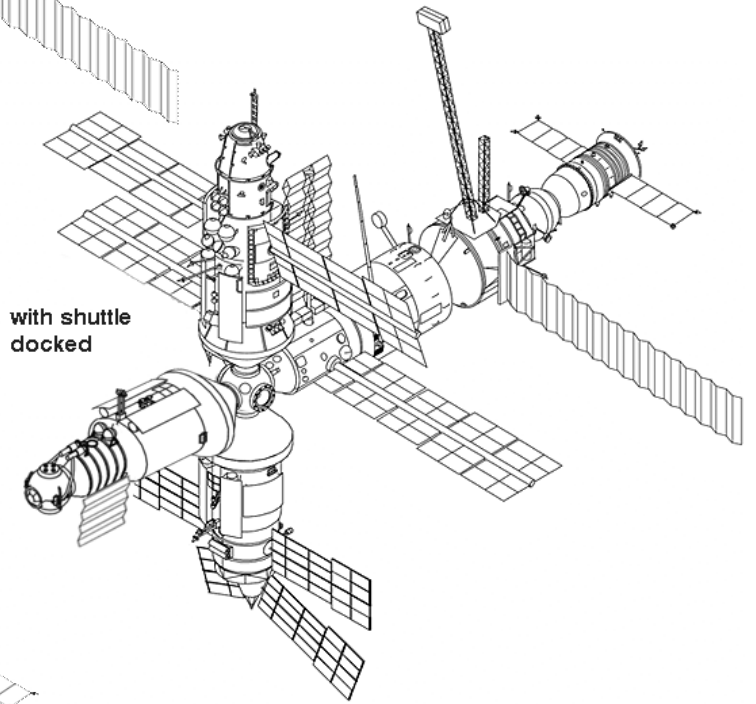

**with shuttle
docked**

**Kristall hosts STS-71 at central port
Jun. 29 thru Jul. 4, 95**

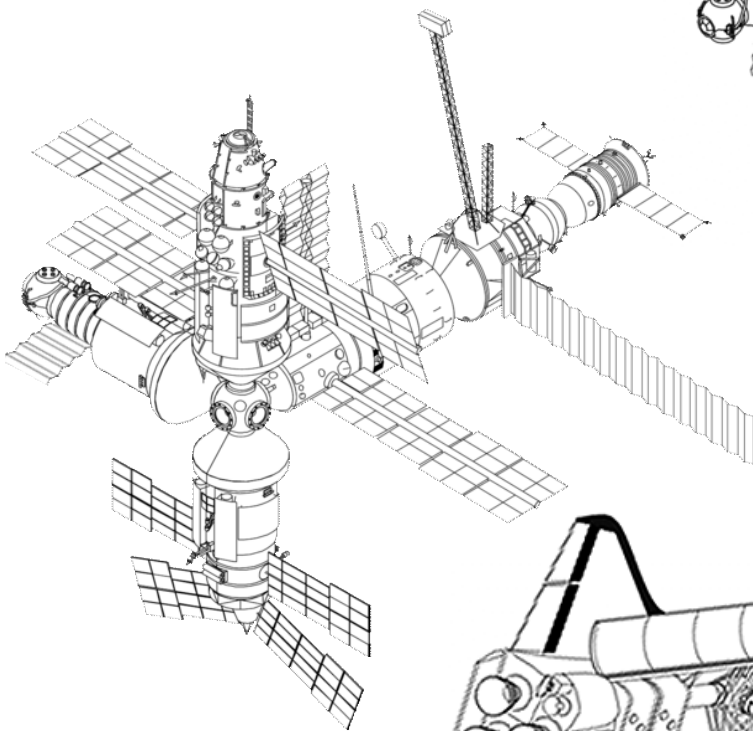

**Kristall repositions
to starboard port Jul. 17, 95
Note Spektr array unfurled
during EVA on Jul. 14, 95**

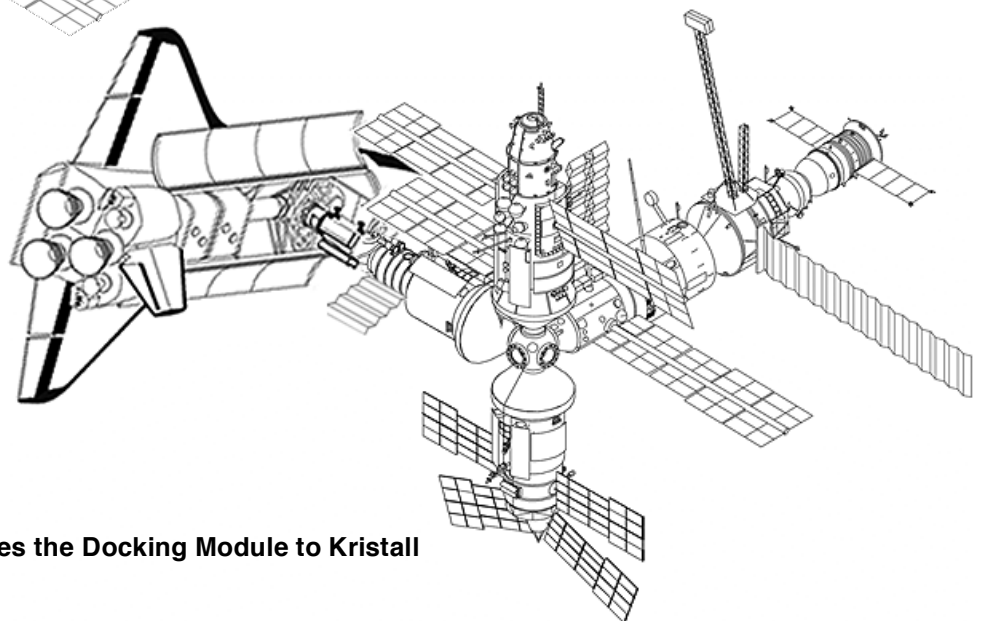

**STS-74 mates the Docking Module to Kristall
Nov. 15, 95**

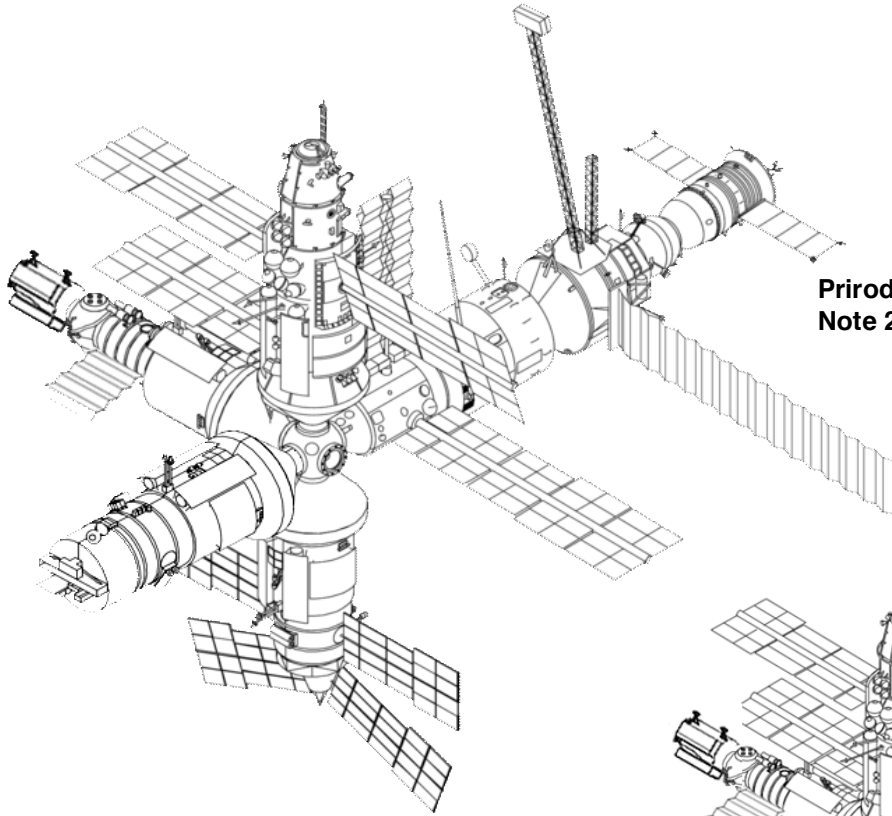

Priroda docks to central port Apr. 26, 96
Note 2nd Strela was added in EVA Mar. 15, 96

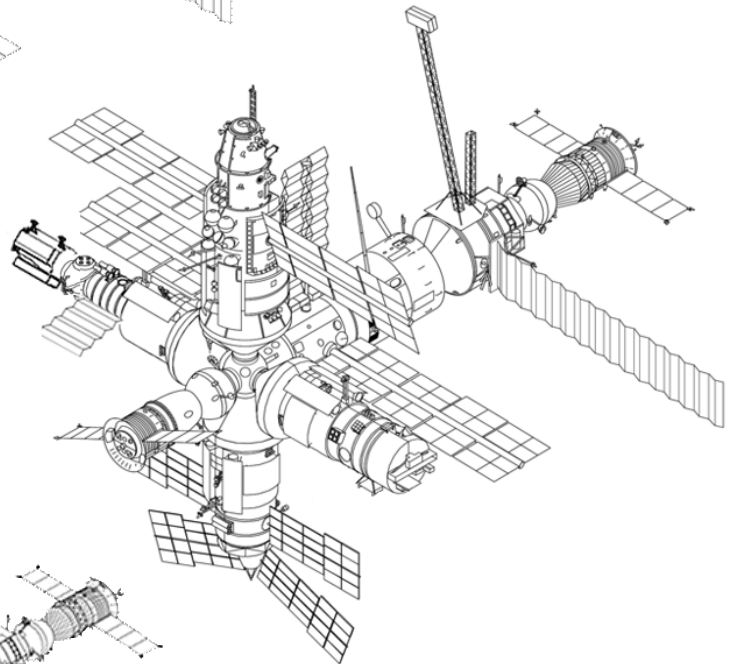

Priroda repositions to port side port
Apr. 27, 96

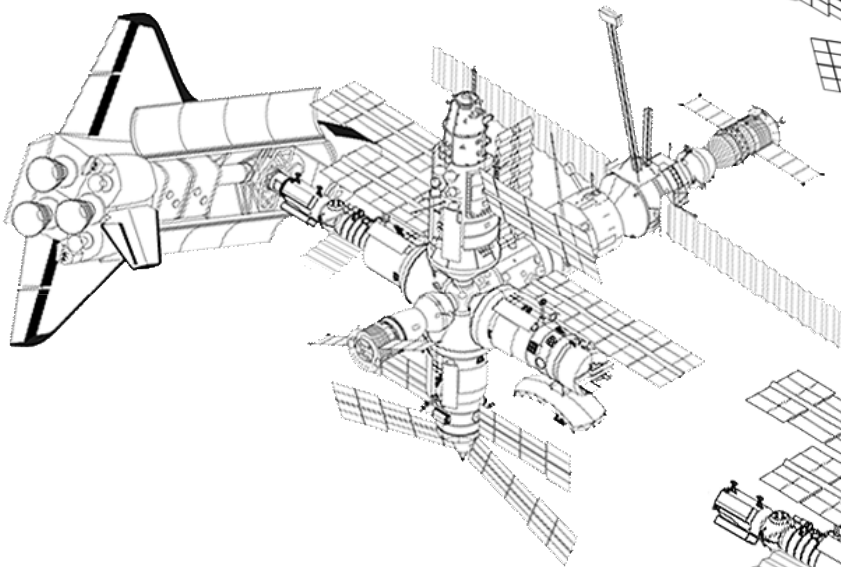

STS-79 docks to Docking Module Sep. 19, 96
Note a new Kvant array stored on the DM added
to the starboard side of Kvant during EVAs In
May, 1996. Also Strombus Mast replaces Rapana
and Priroda Travers Parabolic Antenna unfurled.
Both during an EVA on Jun. 13, 96

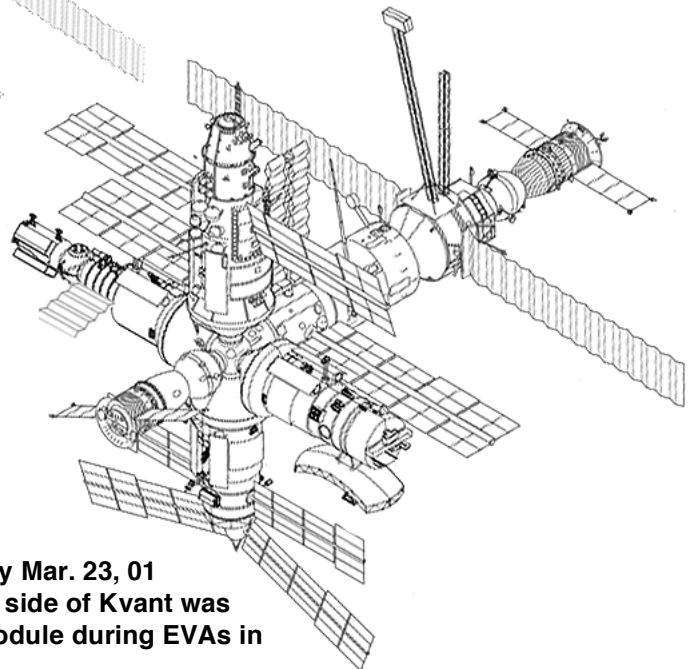

Final Mir Complex configuration till reentry Mar. 23, 01
Note the original Kristall array on the port side of Kvant was
replaced by one stored on the Docking Module during EVAs in
Nov. 97. Also note Rapana Mast added
to the top of the Strombus Mast in an EVA Dec. 2, 96.
Rapana/Strombus masts dismantled in an EVA Apr. 17, 98